

# Datasheet

## Aurawave AW100 Series

Bluetooth™ Auracast™ and LE Audio Module +

Aurawave Audio Framework v1.0 with AT Command Interface

*Version 1.1-r1*

---

## Revision History

Version	Date	Notes	Contributors	Approver
0.1	7 May 2025	Initial version.	Garrett LoVerde	Jonathan Kaye
0.2	12 May 2025	Ezurio branding	Dave Drogowski	Jonathan Kaye
1.0	25 July 2025	Prepare for general availability	Garrett LoVerde	Jonathan Kaye
1.0-r2	24 October 2025	Update temperature range	Garrett LoVerde	Jonathan Kaye
1.1-r1	3 March 2026	Updated to include AW100PA-D variant and correct line-in/out error on system diagram	Paul Faget	Jonathan Kaye

## Contents

1	Introduction	4
2	Terminology	5
3	Introduction	6
3.1	Modes of Operation	6
3.1.1	Standalone Mode	6
3.1.2	Host Mode	6
3.2	Key Features (v1.0)	6
3.3	Aurawave Audio Framework Capabilities (v1.2)	6
3.4	Hardware Features (AW100PA-A-INT)	7
3.5	Hardware Features (AW100PA-D-INT)	8
3.6	Interfaces	9
3.7	Part Numbers and Options	9
4	AW100PA-A Series Hardware Specifications	10
4.1	Mechanical Specifications	10
4.2	System Architecture	11
4.3	Electrical Specifications	12
4.4	40-Pin Connector Pinout	12
5	AW100PA-D Series Hardware Specifications	14
5.1	Mechanical Specifications	14
5.2	System Architecture	15
5.3	Electrical Specifications	16
5.4	40-Pin Connector Pinout	17
6	Aurawave Audio Framework	18
6.1	Software Architecture	18
6.2	Software Pin Assignments	18
6.3	AT Command Interface	19
6.3.1	AT Command Interface Selection	19
6.4	Audio Input	19
6.5	Firmware Update	19
6.6	Button Functions	19
6.7	LED Indications	19
7	References	20
8	Additional Information - Ezurio	21
9	Additional Information - Cloud2GND	22

# 1 Introduction

This document provides a brief product outline of the Aurawave™ AW100 series modules, the Aurawave Audio Framework software, and the functionality they provide when combined.

The document outlines the specific hardware capabilities and interfaces of the Aurawave AW100 series modules including electrical and mechanical specifications. It also provides basic descriptions of the Aurawave Audio Framework's software architecture and operation.

## 2 Terminology

Term	Definition
Auracast™	Bluetooth technology for broadcasting audio to many devices simultaneously
Aurawave AT Command Interface	A serial command and control interface for the Aurawave Audio Framework for runtime configuration and control of the module and LE Audio functionality
Aurawave Audio Framework	Software framework which includes LE audio related middleware with an AT interface for use on Auraware module(s)
Aurawave Module	A module in the Aurawave family of LE audio products
BAP (Basic Audio Profile)	Bluetooth profile for basic audio functionalities, including broadcast audio
BIS (Broadcast Isochronous Stream)	A connectionless Bluetooth data stream used to transmit audio
CAP (Common Audio Profile)	Bluetooth profile for common audio functionalities
Codec	A device or software that encodes and decodes audio signals
GPIO	General Purpose Input/Output
I2C	Inter-Integrated Circuit
I2S (Inter-IC Sound)	A serial bus interface standard for connecting digital audio devices
PBP (Public Broadcast Profile)	Bluetooth profile for public audio broadcasting
QSPI Flash	Quad Serial Peripheral Interface Flash memory
SPI	Serial Peripheral Interface
SWD (Serial Wire Debug)	A debugging interface for ARM processors
TRS (Tip-Ring-Sleeve)	A type of audio connector, commonly used for 3.5mm jacks
UART	Universal Asynchronous Receiver-Transmitter

## 3 Introduction

The primary function of the **Aurawave AW100 series** modules when combined with the **Aurawave Audio Framework** AT command software is to serve as an **Auracast™** transmitter, enabling the wireless broadcasting of high-quality audio to multiple Bluetooth receivers simultaneously. Auracast™ technology is at the forefront of wireless audio streaming, offering a seamless and reliable user experience in environments such as public venues, conference halls, and personal audio setups.

In addition to its Auracast™ capabilities, the module is engineered to act as a flexible Bluetooth LE Audio device, intended to reduce time and design cost to integrate Bluetooth LE audio functionality into customer end devices. This dual functionality allows the module to be integrated into a wide range of use cases, from consumer electronics to industrial applications, where reliable Bluetooth LE connectivity is essential.

### 3.1 Modes of Operation

#### 3.1.1 Standalone Mode

- Initial configuration using AT commands over USB serial port
- Factory default configuration for easy demonstration purposes
- Board powered via USB-C Connector (5v) using standard power supply
- Broadcast line-level analog audio from any device with a 3.5mm jack
- Broadcast digital audio from any device that supports USB Audio class drivers
- Configure, deploy, and forget!

#### 3.1.2 Host Mode

- Standard 40-Pin header for easy integration
- Powered via I/O pins or USB
- AT control interface via UART/GPIO or USB
- Flexible control of stream meta data and configuration
- Audio over I2S, USB, or line-level analog via 40-Pin header

### 3.2 Key Features (v1.0)

Key features of the AW100 series module with included Aurawave Audio Framework Software v1.0:

- **Easy AT Command Interface:** Ships with firmware that enables straight forward configuration and control of Bluetooth Auracast™ broadcasts via AT commands
- **Auracast™ Source Capability:** Broadcast high-quality audio streams to multiple Bluetooth receivers simultaneously, supporting use cases in public and private environments
- **Bluetooth LE 5.4:** Seamlessly integrate with third-party Bluetooth LE devices, offering flexibility for various applications, including audio, data transfer, sensor connectivity
- **Audio Input & Output:** I2S, USB, and onboard codec\* to handle analog and digital audio I/O
- **Standalone Operation:** When powered by common power adapters (USB-C), the Bluetooth LE Auracast™ module will operate without the need for other supporting hardware to broadcast analog audio
- **USB-C Interface:** The Aurawave module can be powered and controlled by a USB-C host device using standard AT-Commands over a virtual serial port while also exposing a digital audio interface
- **40 Pin Expansion Header:** Integrate LE audio into your product via the 40-pin header, which exposes power, serial, audio, GPIO and more
- **Compact and Modular Design:** The module is designed for easy integration into existing hardware setups, with a form factor that suits both consumer and industrial applications
- **Customizable Firmware:** The Aurawave AW100 ships with pre-built binaries to support control using AT commands. The module firmware can also be customized to meet specific application needs by Cloud2GND. A standard 10-pin SWD header is available for the user to flash custom binaries using standard Nordic tools

### 3.3 Aurawave Audio Framework Capabilities (v1.2)

- AT Command Interface

- Configure audio inputs
- Configure broadcast parameters
- Selectable audio source per broadcast channel
- Configuration persistence
- Factory reset
- Enter firmware upgrade mode
- See [Aurawave AW100 Series AT Command Specification](#) for more information.
- Audio Source Options
  - 2 Channels of Analog I/O at 48kHz or 16kHz sampling rate\*
  - 2 Channels of Digital Audio via USB at 48kHz sampling rate
- Auracast™ Transmitter (Public Broadcast Profile)
  - Standard Quality Broadcast (16kHz)
    - Low latency: 16\_2\_1,
    - High reliability: 16\_2\_2
  - High Quality Broadcast (48kHz)
    - Low latency: 48\_2\_1
    - High reliability: 48\_2\_2

\* AW100PA-A variants only

- 1 x Broadcast isochronous group, up to 2 Subgroups<sup>1</sup>
- Encode up to 2 audio input channels simultaneously
- 2 x Broadcast Isochronous Streams with one audio channel per BIS
- Configurable BAP Audio Locations (Mono, Left, Right, Center, etc.)<sup>2</sup>
- Broadcast Encryption
- Supported Bluetooth LE Features & Roles
  - Public Broadcast Profile (PBP) - Public Broadcast Source
  - Common Audio Profile (CAP) - Initiator
  - Basic Audio Profile (BAP) - Broadcast Source
  - Bluetooth Core 6.2
- Firmware Upgrade
  - Firmware upgrade via provided tools
- Push Button Input
  - Factory Reset - Press and hold
  - Firmware upgrade mode - hold on boot
- Custom Firmware/Feature Development
  - Additional services and custom support available.

### 3.4 Hardware Features (AW100PA-A-INT)

- Ezurio BL5340PA Series Module
  - Nordic nRF5340
  - Nordic nRF21540 Front End Module
  - 128/64 MHz Arm Cortex-M33 application processor with 1 MB Flash & 512 KB RAM
  - 64 MHz Arm Cortex-M33 network processor with 256 KB Flash & 64 KB RAM
  - Integrated Antenna
- AKM AK4558 Digital Sigma-Delta CODEC
  - 32-bit depth
  - 108dB Dynamic Range S/N DAC
  - 100dB S/(N+D) DAC

<sup>1</sup> 1 subgroup supported in Software Version 1.0

<sup>2</sup> Feature available in software version 1.1

- 108dB Dynamic Range S/N ADC
- 92dB S/(N+D) ADC
- 32MBit SPI Flash
- 5Vdc Operating Voltage

### 3.5 Hardware Features (AW100PA-D-INT)

- Ezurio BL5340PA Series Module
  - Nordic nRF5340
  - Nordic nRF21540 Front End Module
  - 128/64 MHz Arm Cortex-M33 application processor with 1 MB Flash & 512 KB RAM
  - 64 MHz Arm Cortex-M33 network processor with 256 KB Flash & 64 KB RAM
  - Integrated Antenna
- 16MBit SPI Flash
- 5Vdc Operating Voltage

### 3.6 Interfaces

- Bluetooth Low Energy 6.2
- USB-C Connector
  - 5VDC Power
  - Audio I/O
  - AT Control
- Analog I/O via AKM4558 CODEC\*
  - 3.5mm TRS Stereo Line Input
  - 3.5mm TRS Stereo Line Output
- 40-pin header (2x20 2.54mm pitch)
  - I2S In/Out
  - Line Audio In/Out\*
  - USB
  - I2C
  - SPI
  - UART x2
  - GPIO x5
  - +5V DC
- Pushbutton Control
- 2-Color Green/Blue LED
- SWD Programming Interface
- Analog/PCM Audio\*
  - nRF5340 I2S Controller --> AK4558EN I2S Target --> Line Out
  - Header I2S Controller --> BL5340 I2S Target --> LE Audio
  - Line In --> AK4558EN I2S Controller --> BL5340I2S Target -> LE Audio

### 3.7 Part Numbers and Options

AW100 Series Modules				
Ezurio Part #	Part #	I/O Option	Antenna Option	Availability
453-00062-K2	AW100PA-A-INT	Analog + Digital	Internal	Stock Q3 2025
TBC	AW100PA-D-INT	Digital Only	Internal	Special Order
TBC	AW100PA-A-EXT	Analog + Digital	External	Special Order
TBC	AW100PA-D-EXT	Digital Only	External	Special Order

\* AW100PA-A variants only

## 4 AW100PA-A Series Hardware Specifications

### 4.1 Mechanical Specifications

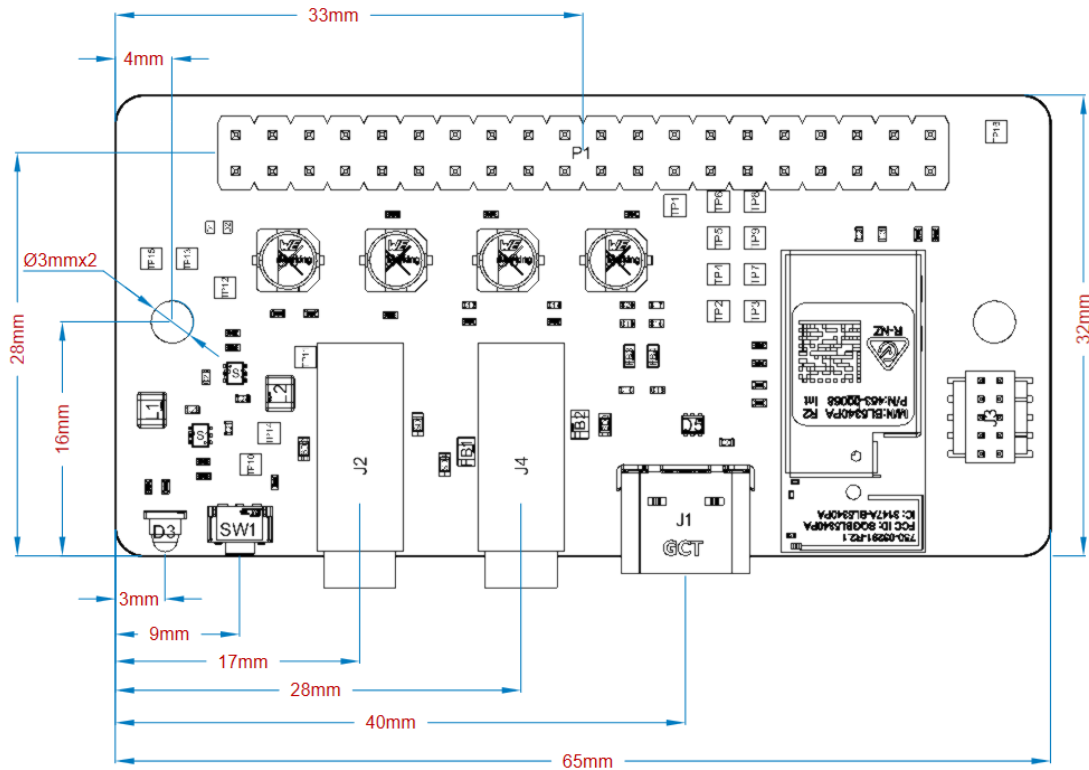

Figure 1 - Aurawave AW100PA-A Dimensions

- 65mm x 32mm
- 2x 3mm mounting holes
- -40C - 85C operating temperature
- RoHS Process
- 1.62mm 6-layer PCB

## 4.2 System Architecture

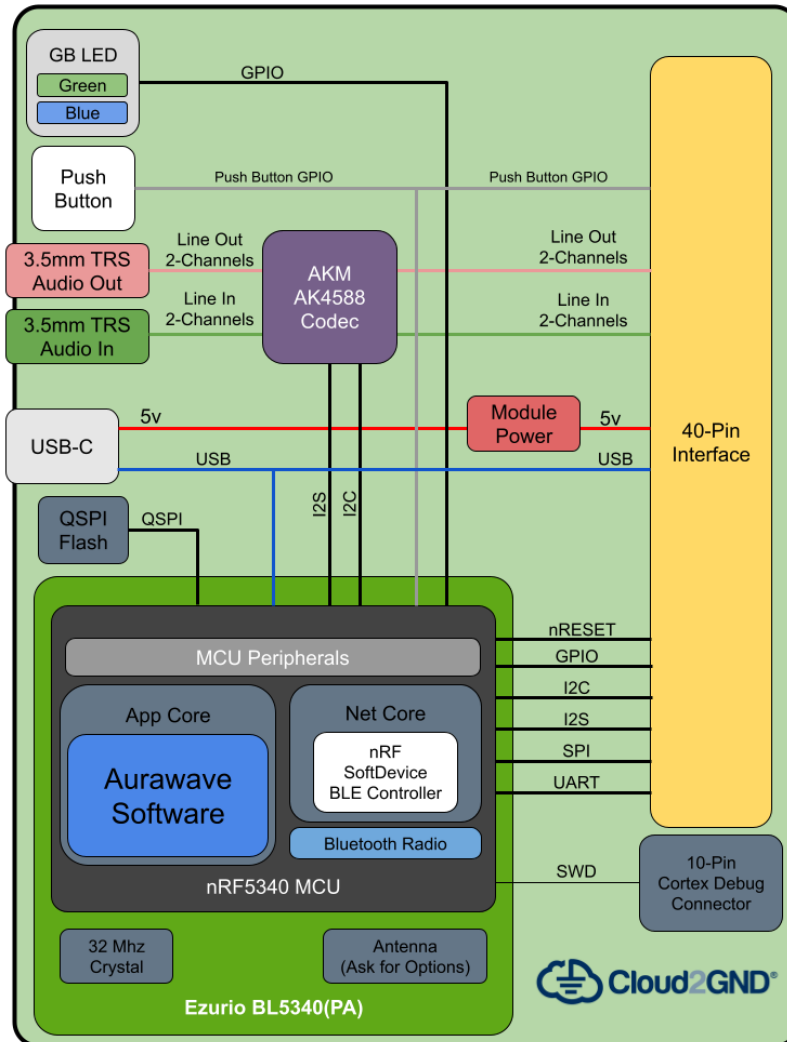

Figure 2 - Aurawave AW100PA-A System Architecture

### 4.3 Electrical Specifications

- 5Vdc operating voltage
- UART, I2C, and I2S lanes operate at 3.3V

#### OPERATING PARAMETERS

Parameter	Min	Typ	Max	Unit
VDD	4.8	5	5.5	V
VBUS - USB	4.35	5	5.5	V
VDD Max Ripple	-	-	10	mV
Current Consumption (Idle)		8.8	29.0	mA
Current Consumption (Broadcast Source)		30.0	45.0	mA
Current Consumption (Broadcast Sink)		23.0	46.5	mA

Current consumption can vary with audio configuration

#### GPIO ELECTRICAL SPECIFICATIONS

Symbol	Parameter	Conditions	Min	Typ	Max	Unit
V_IL	Input Low Voltage		0		0.99	V
V_IH	Input High Voltage		2.31		3.3	V
V_OL	Output Low Voltage		0		0.4	V
V_OH	Output High Voltage		2.9		3.3	V
I_OL	Output Low Current	Std. Drive High-Drive	1 6	2	4	mA
I_OH	Output High Current	Std. Drive High-Drive	1 6	2	3	mA

### 4.4 40-Pin Connector Pinout

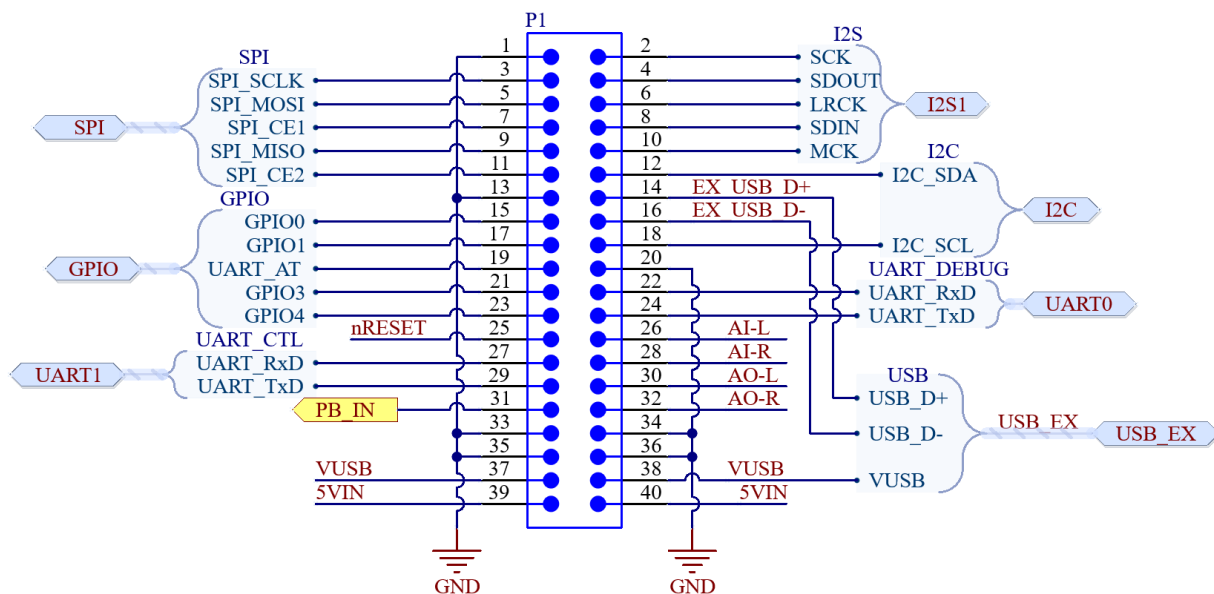

Figure 3 - Aurawave AW100PA-A 40-Pin Connector Pinout

## 40-Pin Connector Pinout (P1)

Pin	Function	Pin	Function	Pin	Function	Pin	Function
1	GND	11	SPI_CE2	21	GPIO3	31	Pushbutton
2	I2S_SCK	12	I2C_SDA	22	UART0_RxD	32	Line Out-R
3	SPI_CLK	13	GND	23	GPIO4	33	GND
4	I2S_SDOUT	14	USB_D+	24	UART0_TxD	34	GND
5	SPI_MOSI	15	GPIO0	25	nRESET	35	GND
6	I2S_LRCK	16	USB_D-	26	Line In-L	36	GND
7	SPI_CE1	17	GPIO1	27	UART1_RxD	37	VUSB
8	I2S_SDIN	18	I2C_SCL	28	Line In-R	38	VUSB
9	SPI_MISO	19	GPIO2	29	UART1_TxD	39	5Vdc
10	I2S_MCK	20	GND	30	Line Out-L	40	5Vdc

## 5 AW100PA-D Series Hardware Specifications

### 5.1 Mechanical Specifications

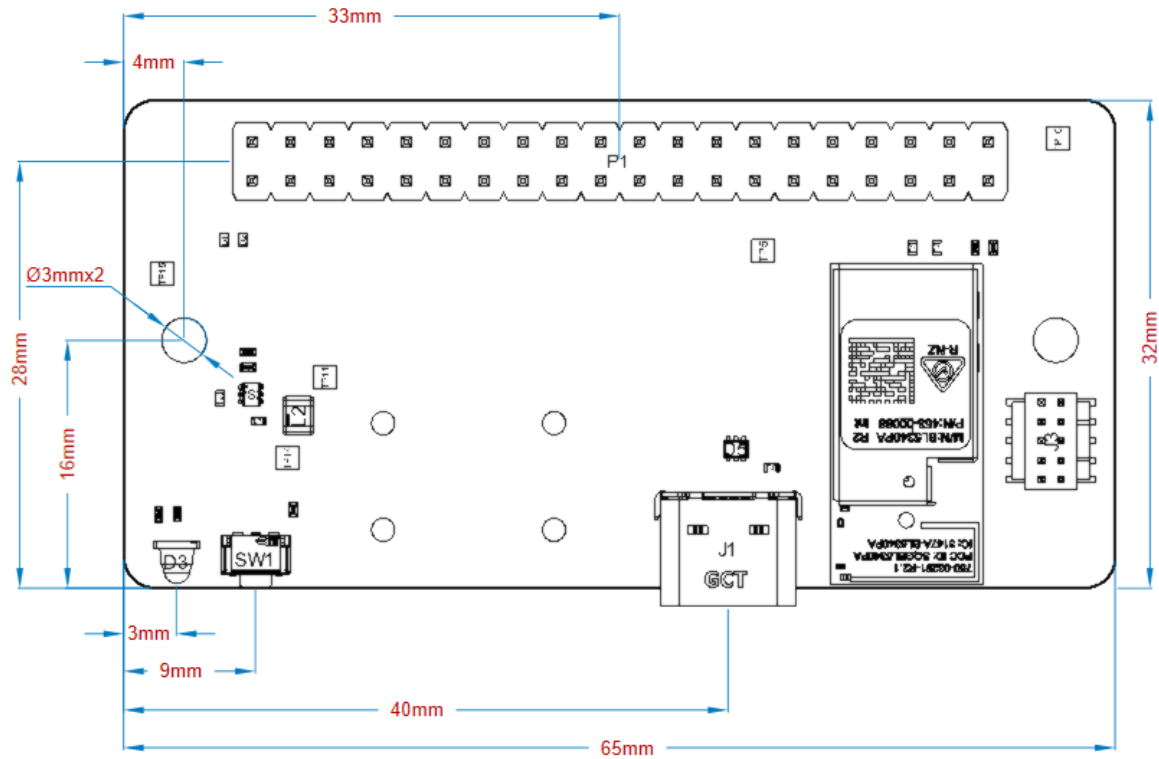

Figure 4 - Aurawave AW100PA-D Dimensions

- 65mm x 32mm
- 2x 3mm mounting holes
- -40C - 85C operating temperature
- RoHS Process
- 1.62mm 6-layer PCB

## 5.2 System Architecture

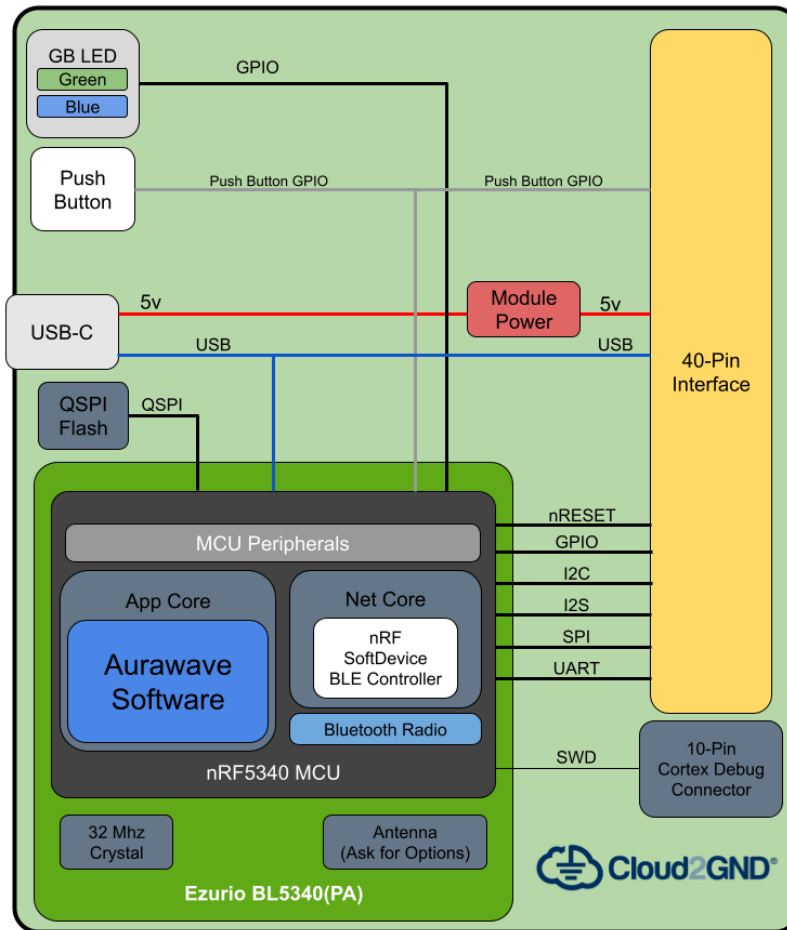

Figure 5 - Aurawave AW100PA-D System Architecture

### 5.3 Electrical Specifications

- 5Vdc operating voltage
- UART, I2C, and I2S lanes operate at 3.3V

#### OPERATING PARAMETERS

Parameter	Min	Typ	Max	Unit
VDD	4.8	5	5.5	V
VBUS - USB	4.35	5	5.5	V
VDD Max Ripple	-	-	10	mV
Current Consumption (Idle)		8.8	23.5	mA
Current Consumption (Broadcast Source)		28.6	38.7	mA

*Current consumption can vary with audio configuration*

#### GPIO ELECTRICAL SPECIFICATIONS

Symbol	Parameter	Conditions	Min	Typ	Max	Unit
V_IL	Input Low Voltage		0		0.99	V
V_IH	Input High Voltage		2.31		3.3	V
V_OL	Output Low Voltage		0		0.4	V
V_OH	Output High Voltage		2.9		3.3	V
I_OL	Output Low Current	Std. Drive High-Drive	1 6	2	4	mA
I_OH	Output High Current	Std. Drive High-Drive	1 6	2	3	mA

### 5.4 40-Pin Connector Pinout

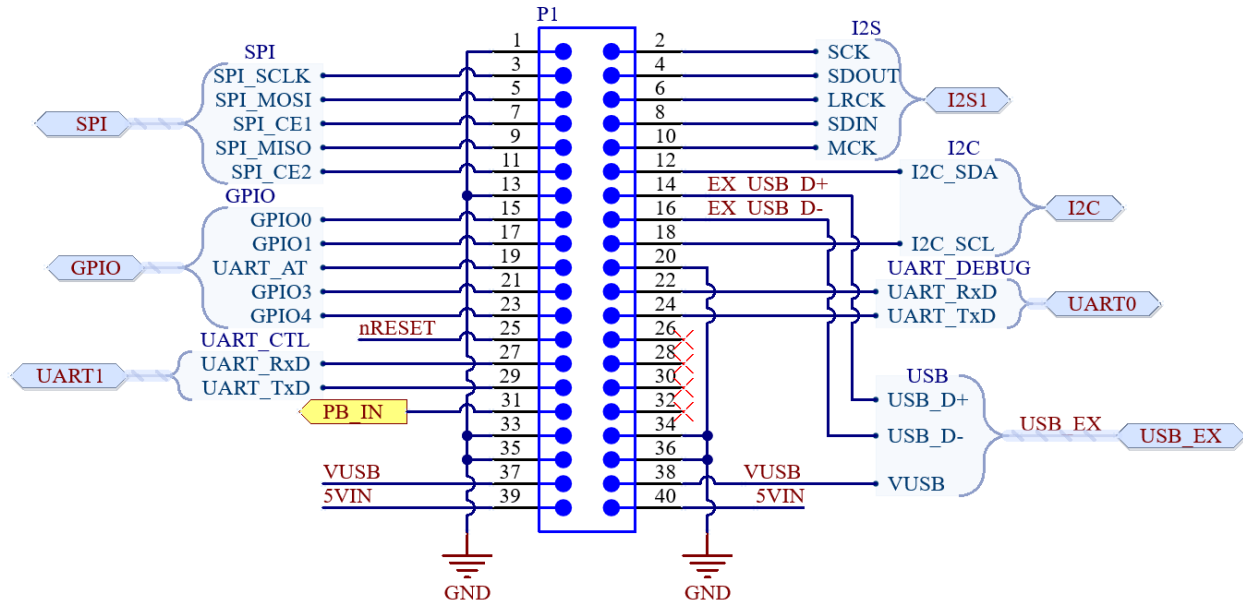

Figure 6 - Aurawave AW100PA-D 40-Pin Connector Pinout

40-Pin Connector Pinout (P1)							
Pin	Function	Pin	Function	Pin	Function	Pin	Function
1	GND	11	SPI_CE2	21	GPIO3	31	Pushbutton
2	I2S_SCK	12	I2C_SDA	22	UART0_RxD	32	NC
3	SPI_CLK	13	GND	23	GPIO4	33	GND
4	I2S_SDOUT	14	USB_D+	24	UART0_TxD	34	GND
5	SPI_MOSI	15	GPIO0	25	nRESET	35	GND
6	I2S_LRCK	16	USB_D-	26	NC	36	GND
7	SPI_CE1	17	GPIO1	27	UART1_RxD	37	VUSB
8	I2S_SDIN	18	I2C_SCL	28	NC	38	VUSB
9	SPI_MISO	19	GPIO2	29	UART1_TxD	39	5Vdc
10	I2S_MCK	20	GND	30	NC	40	5Vdc

## 6 Aurawave Audio Framework

### 6.1 Software Architecture

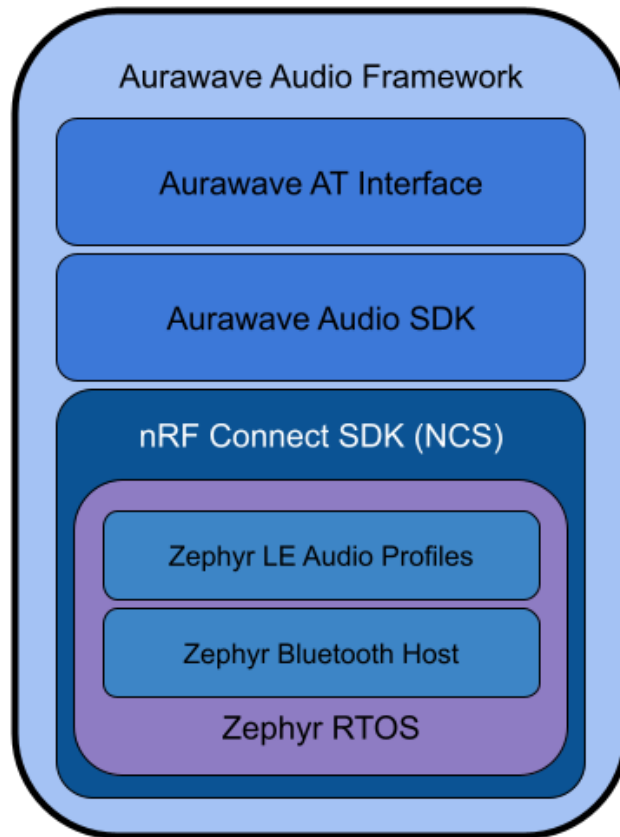

Figure 7 - Aurawave AW100 Software Architecture

### 6.2 Software Pin Assignments

AT Software - 40-Pin Connector Functions (P1)							
Pin	Function	Pin	Function	Pin	Function	Pin	Function
1	GND	11	UNUSED	21	UNUSED	31	Pushbutton
2	I2S_SCK	12	I2C_SDA	22	UNUSED	32	Line Out-R
3	UNUSED	13	GND	23	UNUSED	33	GND
4	I2S_SDOOUT	14	USB_D+	24	UNUSED	34	GND
5	UNUSED	15	UNUSED	25	nRESET	35	GND
6	I2S_LRCK	16	USB_D-	26	Line In-L	36	GND
7	UNUSED	17	UNUSED	27	UART_AT_RxD	37	VUSB
8	I2S_SDIN	18	I2C_SCL	28	Line In-R	38	VUSB
9	UNUSED	19	AT_SELECT	29	UART_AT_TxD	39	5Vdc
10	I2S_MCK	20	GND	30	Line Out-L	40	5Vdc

## 6.3 AT Command Interface

- See [Aurawave AW100 Series AT Command Specification](#)
- Hosted via USB CDC (115200 Baud) by default
- Can be configured to operate via UART exposed on 40-Pin header (UART\_CTL)

### 6.3.1 AT Command Interface Selection

To configure the AT interface to use UART\_CTL instead of the USB CDC port use the following procedure:

- Ensure Aurawave module is unpowered
- Short Pin 19 to GND. Pin 20 of 40-Pin Header is convenient
- Apply power to Aurawave module
- Use 3.3v logic when writing to UART\_AT\_RxD (P1 - Pin 27) and reading from UART\_AT\_TxD (P1 -Pin 29)

## 6.4 Audio Input

- Analog\* or USB input
- Analog through 3.5mm jacks or 40-pin connector (selected automatically on jack insertion)\*
- Audio input device selectable via AT command and can be changed mid-broadcast

## 6.5 Firmware Update

- See [Aurawave AW100 Series Firmware Upgrade Guide](#) for instruction
- Firmware update mode can be entered by holding the module's button while applying power and until the LED indicates firmware update mode has been entered
- Firmware update mode also activated via AT command
- Updates are transferred via USB CDC serial port & MCUmgr protocol

## 6.6 Button Functions

Function	Context	Action
Factory Reset	Anytime after boot	Press and hold (5 Seconds)
Firmware Update mode	Before and as power is applied	Press and hold

## 6.7 LED Indications

Indication	LED State
Firmware Update Mode	GREEN ON
Auracast Active	BLUE ON
Factory Reset Ready	CYAN Fast Blink
Unpowered	OFF

\* AW100PA-A variants only

## 7 References

Ref	Information
A	<i><a href="#">AW100 Product Brief (EZ-PB-AW100-Series)</a></i>
B	<i><a href="#">Aurawave AW100 Series AT Command Specification</a></i>
C	<i><a href="#">Datasheet - BL5340PA Series   Ezurio</a></i>
D	<i><a href="#">nRF5340 Product Specification</a></i>
E	<i><a href="#">nRF21540 Product Specification</a></i>
F	<i><a href="#">AK4558 English Datasheet</a></i>
G	<i><a href="#">Aurawave AW100 Series Firmware Upgrade Guide</a></i>

## 8 Additional Information - Ezurio

Please contact your local sales representative or our support team for further assistance:

<b>Headquarters</b>	Ezurio 50 S. Main St. Suite 1100 Akron, OH 44308 USA
<b>Website</b>	<a href="http://www.ezurio.com">http://www.ezurio.com</a>
<b>Technical Support</b>	<a href="http://www.ezurio.com/resources/support">http://www.ezurio.com/resources/support</a>
<b>Sales Contact</b>	<a href="http://www.ezurio.com/contact">http://www.ezurio.com/contact</a>

**Note:** Information contained in this document is subject to change.

## 9 Additional Information – Cloud2GND

---

<b>Headquarters</b>	Cloud2GND 4500 Bowling Blvd #100 Louisville, KY 40207
<b>Website</b>	<a href="http://www.cloud2gnd.com/">http://www.cloud2gnd.com/</a>
<b>Technical Support</b>	<a href="https://cloud2gnd.com/contact/">https://cloud2gnd.com/contact/</a>

---

Ezurio's products are subject to standard [Terms & Conditions](#).

---

© Copyright 2026 Ezurio All Rights Reserved. Any information furnished by Ezurio and its agents is believed to be accurate but cannot be guaranteed. All specifications are subject to change without notice. Responsibility for the use and application of Ezurio materials or products rests with the end user since Ezurio and its agents cannot be aware of all potential uses. Ezurio makes no warranties as to non-infringement nor as to the fitness, merchantability, or sustainability of any Ezurio materials or products for any specific or general uses. Ezurio or any of its affiliates or agents shall not be liable for incidental or consequential damages of any kind. All Ezurio products are sold pursuant to the Ezurio Terms and Conditions of Sale in effect from time to time, a copy of which will be furnished upon request. Nothing herein provides a license under any Ezurio or any third-party intellectual property right. Ezurio and its associated logos are trademarks owned by Ezurio and/or its affiliates.

---